

# **The Florida House of Representatives**

## **Economic Expansion & Infrastructure Council**

**Marco Rubio**  
Speaker

**Dean Cannon**  
Chair

February 5, 2007

### **AGENDA**

**February 8, 2007**  
**1:30 pm – 3:00 pm**  
**404 HOB**

- 1. Welcome, call to order and roll call – Chair Dean Cannon**
- 2. Governor’s Policy and Budget Recommendations for FY 2007-2008:**
  - **Lisa Saliba, Policy Coordinator for Transportation & Economic Development**
  - **Randy Ball, Policy Coordinator for Public Safety**
- 3. Closing comments – Chair Cannon**
- 4. Adjourn**

# **Governor Charlie Crist**

## **Lt. Governor Jeff Kottkamp**

The People's Governor



The People's Budget

*Policy and Budget Recommendations*

*Fiscal Year 2007-08*

**Governor Crist's Budget Recommendations  
for  
Transportation and Economic Development  
Fiscal Year 2007-08**

Presented to the House Economic Expansion  
and Infrastructure Council

February 8, 2007

# FY 2007-08 Governor's Recommended Budget

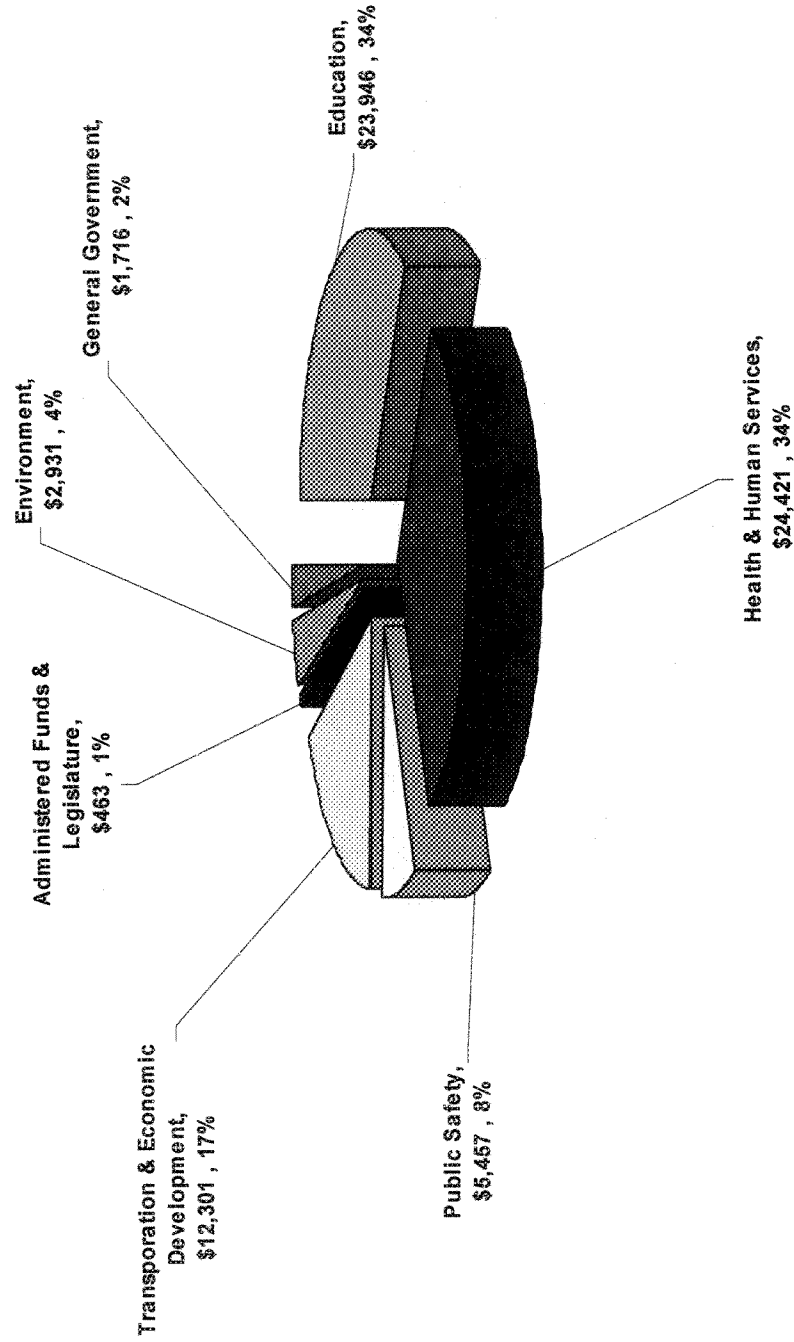

Note: The Public Safety Budget includes the Departments of Corrections, Juvenile Justice, Law Enforcement, Legal Affairs, Military Affairs, Highway Safety and Motor Vehicles, the Parole Commission, Justice Administration Commission and the State Courts.

## **Department of Highway Safety and Motor Vehicles**

Total recommended budget - \$435.8 million

- 5% increase for Troopers
- Longevity increase for Troopers - \$500 increase per year of service up to a maximum of \$5,000
- \$1.2 million – increase in operations of motor vehicles

## **Department of Highway Safety and Motor Vehicles (cont.)**

- \$853K – Building rent
- \$491K – Purchase of Driver Licenses
- \$394K – Purchase of License Plates and Decals
- \$250K – Desktop Contract Maintenance

# Comparison of General Revenue and Trust Funds

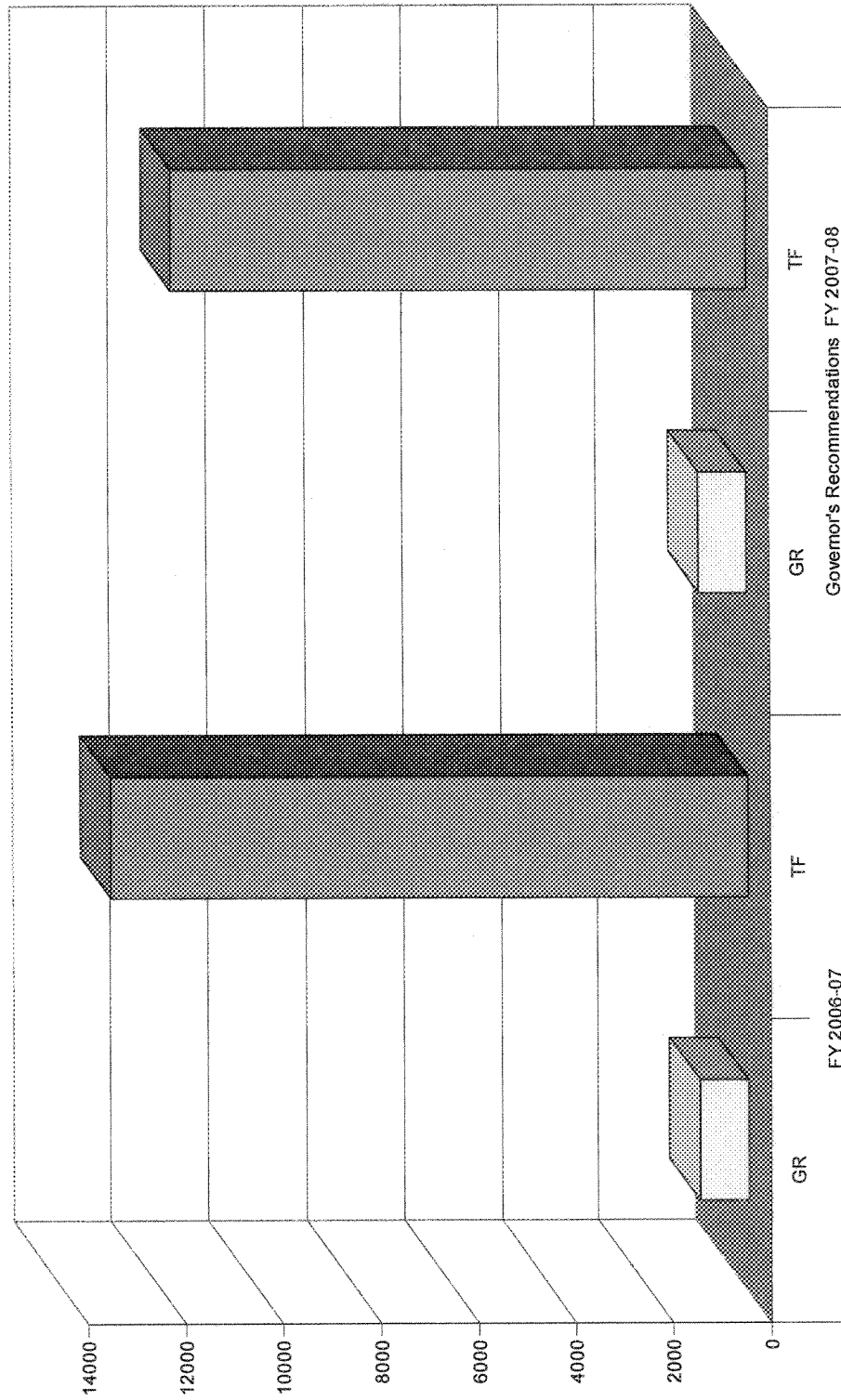

**Full Time Positions increase from 15,226.49 to 15,243.49**

# Increase over Recurring Base Budget

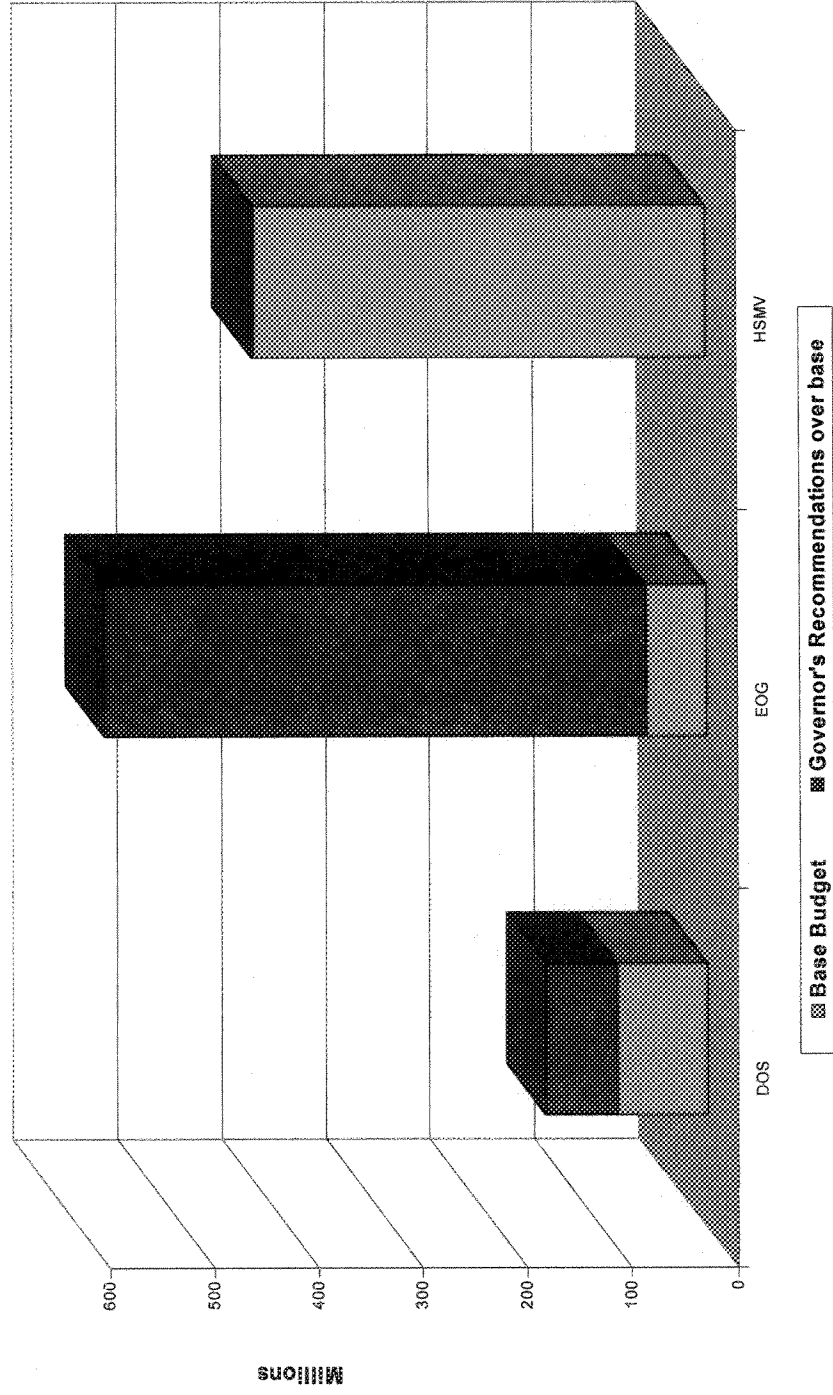



# Increase over Recurring Base Budget

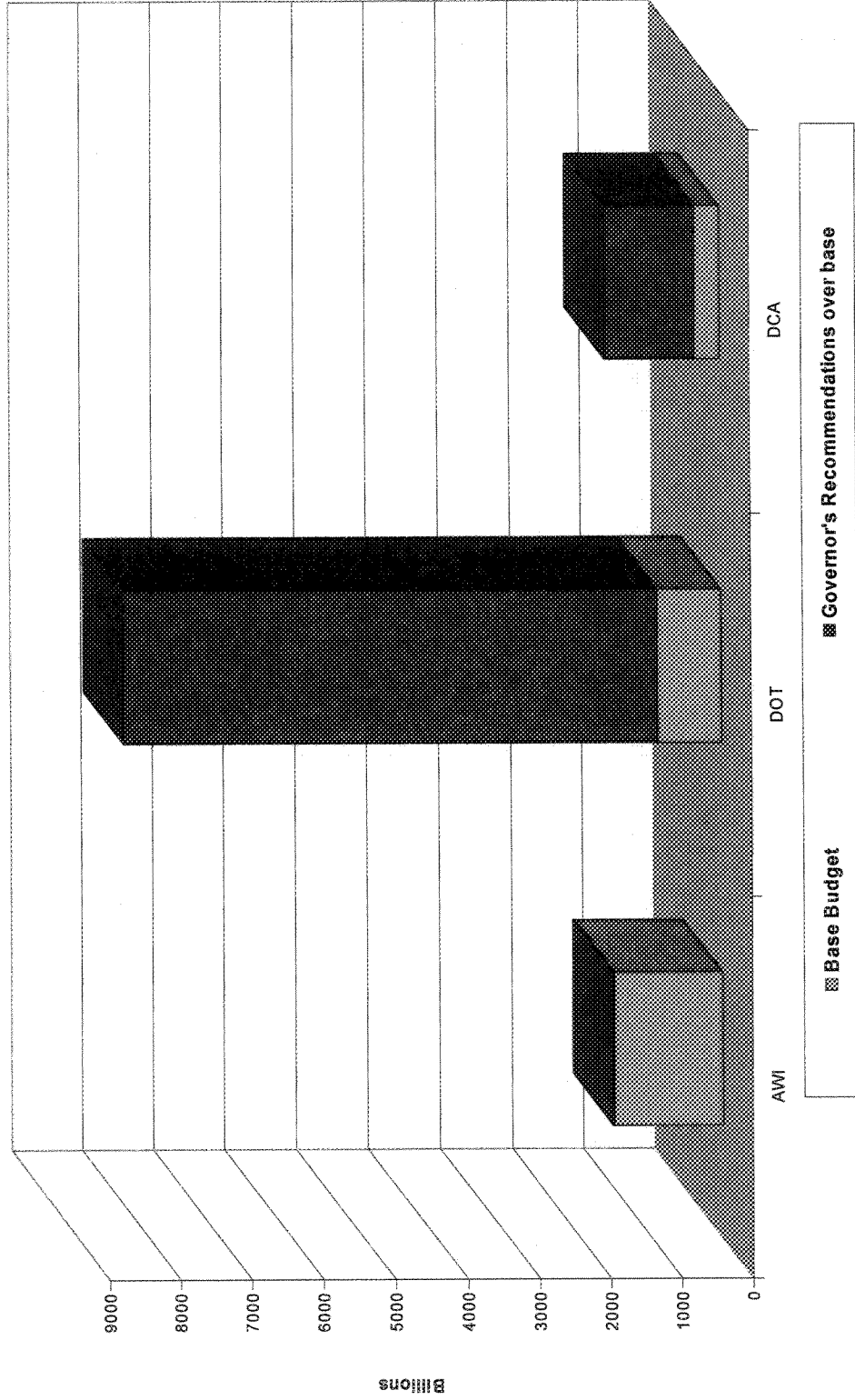

# Transportation and Economic Development — Priorities

- **\$32.5 million** — Voting Machine Paper Trail
  - Restore voter confidence in Florida's election system
- **\$260 million** — Economic Development
  - \$100 million — 2nd Year funding for the Innovation Incentive Fund to attract high-value, high-impact businesses and research and development projects
  - \$75 million — Enhanced Film and Entertainment Incentives to attract film and television productions to Florida
  - \$40 million — Inaugural Funding for Alternative Energy Incentives to explore new fuel sources
  - \$45 million — Continued funding for the Quick Action Closing Fund to provide Florida with a viable competitive edge for attracting and retaining businesses

# Transportation and Economic Development – Summary

- \$7.4 billion – Transportation Work Program
- \$1.1 billion – Emergency Management Disaster funding
- \$19.2 million – Cultural and Historic Grants
- \$2.4 million – Library Cooperative Grants
- \$76.2 million – Other Economic Development

# Agency for Workforce Innovation

Total Budget \$1,543,053,508

- \$657.9 million – School Readiness
- \$388.1 million – Voluntary Prekindergarten
- \$4 million – Incumbent Worker Program
- \$22.3 million – Child Care Development Block Grant

# Department of Community Affairs

**Total Budget \$1,617,853,498**

- **\$1.6 million** – Technical Assistance and Planning Grants
- **\$3.3 million** – Regional Planning Councils
- **\$3.0 million** – Front Porch Florida
- **\$0.5 million** – Hurricane Resistant Construction Testing and Standards Development
- **\$66 million** – Land Acquisition
- **\$35 million** – Community Development Block Grant

# Department of Community Affairs

## Division of Emergency Management

Total Budget \$1,183,419,407

- \$1.1 billion -- Federal Declared Disaster Funding
- \$8.2 million -- Pre-Disaster Mitigation Program
- \$4.0 million -- Repetitive Flood Claims Program
- \$9.9 million -- Hurricane Catastrophe Fund Programs
- \$6.5 million -- Emergency Power for Special Needs Shelters

# Executive Office of the Governor

## Office of Tourism, Trade, and Economic Development

Total Budget \$542,096,349

- \$100 million -- Innovation Incentive Fund
- \$75.0 million -- Enhanced Film and Entertainment Incentives
- \$40.0 million -- Inaugural Funding for Alternative Energy Incentives
- \$45.0 million -- Quick Action Closing Fund
- \$22.8 million -- Economic Development Tools
- \$12.0 million -- Enterprise Florida, Inc.
- \$6.4 million -- Florida Commission on Tourism
- \$7.0 million -- Space Florida

# Department of State

**Total Budget \$154,530,300**

- **\$32.5 million** – Voting Machine Paper Trail
- **\$5.0 million** – Poll Worker Training / Voter Education
- **\$17.2 million** – Cultural Affairs Grants
- **\$1.75 million** – Historic Museum Grants
- **\$2.0 million** – Historic Preservation Grants
- **\$2.4 million** – Library Cooperative Grant Program
- **\$3.6 million** – Museum Program



# Department of Transportation

Total Budget \$8,379,712,477

- \$7.4 billion -- Transportation Work Program
- \$113.3 million -- Transportation Disadvantaged
- \$1.5 million -- SunPass Processing Center
- \$11.1 million -- Motor Carrier Safety Assistance Program
- \$1.1 million -- Intelligent Transportation System
- \$3.2 million -- Highway Lighting Utility Costs
- \$1.8 million -- Troop K and Motor Carrier Dispatch Services

**Governor Crist's Budget Recommendations  
for  
Transportation and Economic Development  
Fiscal Year 2007-08**